

## IMPACT OF TCSC ON THE TRANSIENT STABILITY

Zsolt ČONKA, Michal KOLCUN

Department of Electric Power Engineering, Faculty of Electrical Engineering and Informatics, Technical University of Košice,  
Letná 9, 042 00 Košice, Slovak Republic, e-mail: zsolt.conka@tuke.sk, michal.kolcun@tuke.sk

### ABSTRACT

*This paper describes the impact of TCSC (thyristors controlled series compensator) on the transient stability of the electricity transmission. Line reactance and the power flow can be changed by TCSC. TCSC can help to better course of the transient phenomenon ongoing in the power system (PS). TCSC is the one of the best ways to improve the transient stability of the power transmission system.*

**Keywords:** transient stability, TCSC, power system.

### 1. INTRODUCTION

At the end of 1980, electric power research institute EPRI (Electric Power Research Institute) formulated a vision of FACTS (Flexible AC Transmission Systems), which regulators are based on power electronics for controlling the power flow and for reduce transmission voltage fluctuations in the power transmission system. The general rule is that the main task of FACTS devices is to increase the transmission capacity of the existing lines and control the power flows [1].

The transient stability of the power system are influenced by many factors such as. (admittance, duration of fault, actuating of the generator). Probability of stability depends on the size of the transmitted power, just prior to failure [3]. TCSC allows us to smooth change of admittance, which is a very important variable that affecting the stability of the system.

### 2. COUPLING ADMITANCIA

An interaction between generators in the system indicates coupling admittance. Enlargement of the admittance, before, after or during disturbances has a positive effect on the transient stability of the system. Increasing coupling admittance can be achieved by reducing the coupling impedance. Coupling impedance we can reduce with a few methods.

Reducing the reactance of the existing machines is impossible. The coupling impedance  $Z_{ij}$  is determined by a combination of individual elements of the PS. It follows that to improve the stability it is necessary to reduce the reactance of the generators, transformers and lines.

Reducing of the line reactance is possible with using a bunch lines. Using of the bunch lines, the reactance of lines are reduced by 20% to 30%.

Another possibility of indirect impedance changes is the inclusion of different compensators and FACTS devices [2].

### 3. TRANSIENT STABILITY

Synchronous machines are interconnected through transformers and lines and they are in parallel and synchronous operation. The transfer capability of such systems is limited by the permissible voltage drops and

with the power handling capacity. At transmission to the large distance been treated the condition of stability of parallel operation. Synchronization power of synchronous machine allows us to so synchronous operation. This power presents the increase of the transmitted power at an increasing of the load angle of generator rotor over  $1^\circ$  [2, 3].

The swing of generator rotor due to changes of the electromagnetic energy which is accumulated in the magnetic circuits of the machine so arises additional power. This power can take positive but also negative values, which is reflected as a contribution to the performance of  $\Delta P$  as a braking, or acceleration of the machine.

The role of synchronous machines not the retention of the synchronism. Co-operation of synchronous machines cannot be at arbitrarily large power. The Steady-state operation of whole system is depends on the electrical, mechanical and electromagnetic parameters of

The considerations of static stability we can apply for small swings of the machine. In operation, there are many sudden changes in the system (switching processes, shock loads, short circuits). Due to the unbalance of the consumption and production of the electric power the load angle values can achieve major changes. These marches change the load angle with leap. After these changes the system goes into the new system state with electromechanical oscillations. Inertia of the machine not allow an immediate change of operating parameters (angle  $\delta$ ) course of these oscillations may be such as that the angle stabilizes at a new constant, or continue to increasing. In the latter case there is a loss of stability [2, 3].

### 4. TCSC

TCSC configurations comprise controlled reactors in parallel with sections of a capacitor bank. This combination allows smooth control of the fundamental frequency capacitive reactance over a wide range. The capacitor bank of each phase is mounted on a platform to enable full insulation to ground. The thyristor valve contains a string of series connected high power thyristors. The inductor is of air-core design. A metaloxide varistor (MOV) is connected across the capacitor to prevent overvoltage. [6].

The Fig.1 shows the main diagram of TCSC. It consists of 3 parts: capacitor battery C, parallel connected reactor L and the thyristors VT1 and VT2 [4].

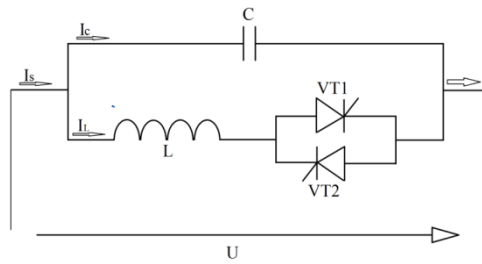

Fig. 1 Engagement of TCSC

$$i_c = C \cdot \frac{dv}{dt} \tag{1}$$

$$i_L = L \cdot \frac{di_L}{dt} \tag{2}$$

$$i_s = i_c + i_L \tag{3}$$

where

$I_C$  and  $I_L$  is the instantaneous capacitor and reactor current

$i_s$  is the instantaneous current of controlled line

$U$  is the voltage of TCSC

TCSC can be controlled by changing the opening angle of the thyristors  $\alpha$ , which is modifying the frequency of the capacitor. Relationship (1) gives the relationship between the opening angle of the thyristor ( $\alpha$ ) and reactance  $X_{TCSC}(\alpha)$  [4].

$$X_{TCSC}(\alpha) = X_C - \frac{X_C^2}{(X_C - X_P)} \cdot \frac{\sigma + \sin\sigma}{\pi} + \frac{4X_C^2}{(X_C - X_P)} \cdot \frac{\cos^2\left(\frac{\sigma}{2}\right) \cdot \left(k \cdot \operatorname{tg}\left(\frac{k \cdot \sigma}{2}\right) - \tan\left(\frac{\sigma}{2}\right)\right)}{(k^2 - 1)} \tag{4}$$

where

$X_C$  is the capacitor capacitance

$X_P$  is the inductive reactance of the reactor

$\sigma = 2(\pi - \alpha) =$  opening angle of TCSC controller

$k = \sqrt{\frac{X_C}{X_P}} =$  compensation ratio

TCSC can operate in capacitive or inductive mode, but the transition from one mode to another we must avoid resonance.

The Control range of TCSC is:

$$X_{TCSC}(\min) \leq X_{TCSC}(\alpha) \leq X_{TCSC}(\max), \tag{5}$$

where

$$X_{TCSC}(\min) = X_{TCSC}(180^\circ) - \text{thyristor in permeable state}$$

$$X_{TCSC}(\max) = X_{TCSC}(\alpha_{\min}), - \text{thyristor in trailing state [4].}$$

### 5. SIMULATION

To demonstrate the impact of TCSC on the transient stability we are modeled three networks.

The first example is a simple network with a synchronous generator whose power is transferred to system by parallel lines. At time  $t = 0.2$  s will due to short-circuit failure of one of the parallel lines. Due to the failure comes to a rotor swings. These examples are simulated in the trial version of simulation program NEPLAN. In the first case, the simulation is without TCSC and in the second case involved the TCSC.

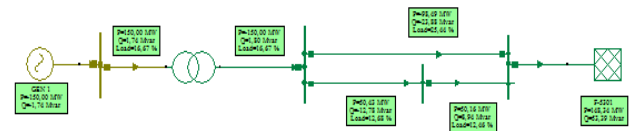

Fig. 2 Engagement without TCSC

For control TCSC was used automatic controller (Fig. 3). The actual transmitted power with lines is the input to the controller. Opening angle of the thyristors is controlled by a regulator. The controller managed the reactance of TCSC according to the current transmitted power.

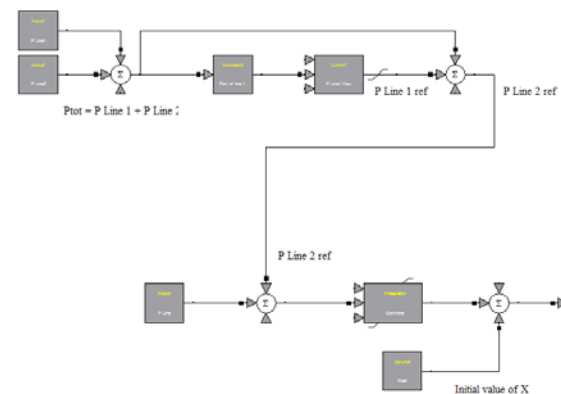

Fig.3 TCSC controller

Failure of one of the parallel lines occurs due to short circuit. On figure 4 we see that the power generator begins to swing and fall out of sync.

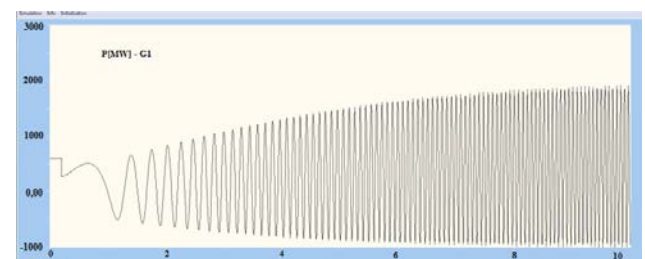

Fig. 4 Power swing without TCSC

Figure 5 shows the networks with TCSC. The power of the generator after fault begins to swing. TCSC will prevent the loss of sync of the generator. Swing of the

generator is stabilized after a few seconds and the network operates with one line.

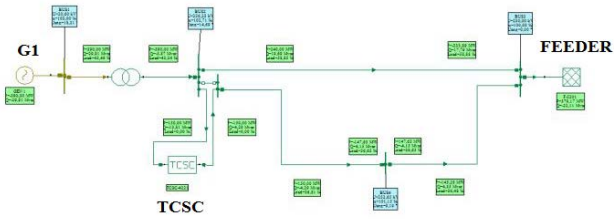

Fig. 5 Engagement with TCSC

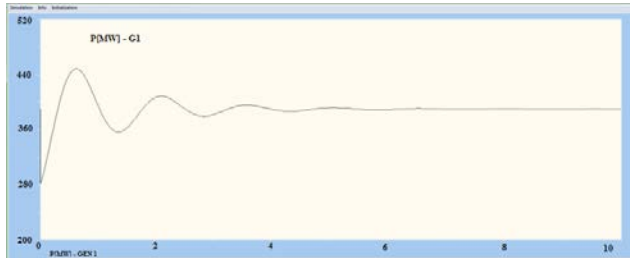

Fig. 6 Power swing with TCSC

The second example is a two generator network (Fig. 7). At t = 0 s will turn off the generator no. 2.

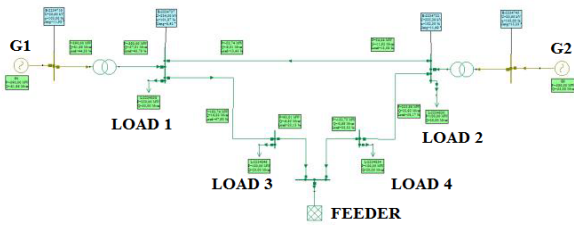

Fig. 7 Two generator network without TCSC

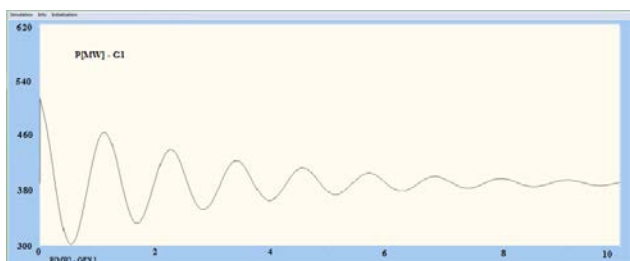

Fig. 8 Power swing of generator no. 1 without TCSC

Swing of the active power of the generator no.1 is big and the settling time of the fluctuations is several seconds.

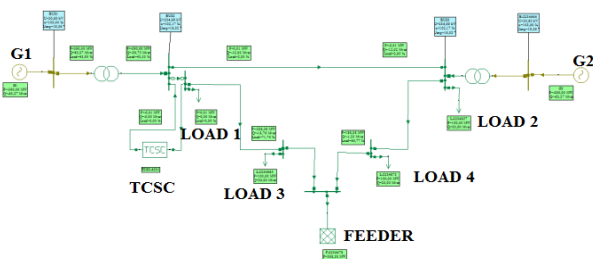

Fig. 9 Two generator network with TCSC

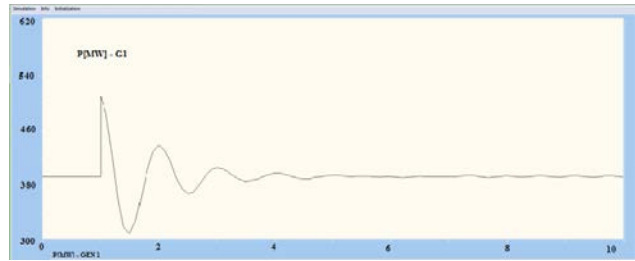

Fig. 10 Power swing of generator no. 1 with TCSC

After connecting TCSC to the network (Fig. 9), the swing of the generator is reduced (Fig. 10) and the settling time is shorter than without TCSC.

The Third example is an IEEE 14 node test network with four generators (Fig. 11). At t = 0 s will turn off the generator no. 4.

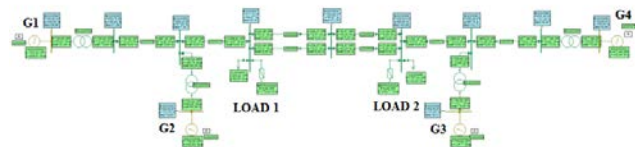

Fig. 11 IEEE 14 node test network without TCSC

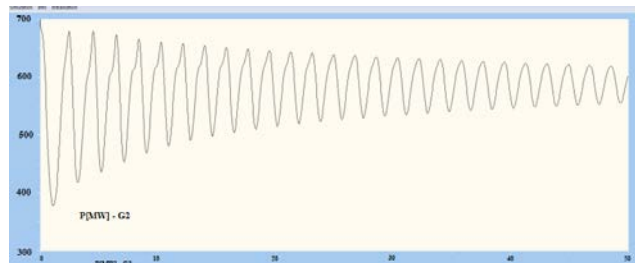

Fig. 12 Power swing of generator no. 2 without TCSC

Swing of the active power of the generator is 300 MW and the settling time of the fluctuations is several seconds.

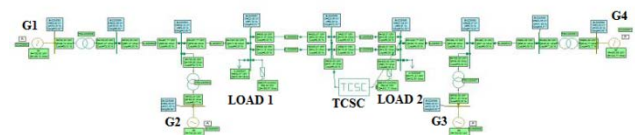

Fig. 13 IEEE 14 node test network with TCSC

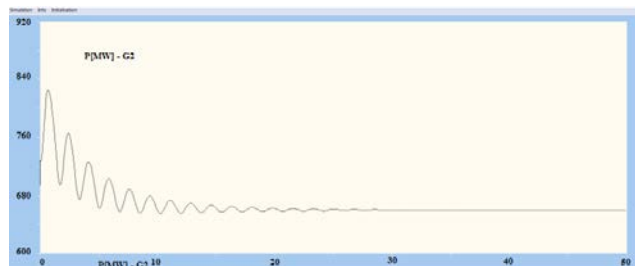

Fig. 14 Power swing of generator no. 2 with TCSC

After connecting TCSC to the network (Fig. 13), the swing of the generator is reduced to 120 MW (Fig. 14)

and the settling time is shorter than without TCSC.

Those three models show the positive effect of the TCSC on the transient stability of the system and can help to get the better reliability of electricity supply. If we prevent loss of sync, we can prevent "chain reaction". This means that a failure of the single generator with big power may lead to further overload of the next generator and to his subsequent failure to. This "chain reaction" can lead to worst possible situation and that is Black out.

#### ACKNOWLEDGMENT

This work was supported by Scientific Grant Agency of the Ministry of Education of Slovak Republic and the Slovak Academy of Sciences under the contract No. 1/0388/13 and by Slovak Research and Development Agency.

#### REFERENCES

- [1] ABIDO, M. A.: Power system stability enhancement using FACTS controllers [online]. Available on the Internet: <[http://ajse.kfupm.edu.sa/articles/341B\\_P.12.pdf](http://ajse.kfupm.edu.sa/articles/341B_P.12.pdf)>.
- [2] TROJÁNEK, Z. – HÁJEK, J. – KVASNICA, P.: Prěchodné jevy v elektrizačných soustavách. STNL, 1987. 202 – 231 s.
- [3] REISS, L. – MALÝ, K. – PAVÍČEK, Z. – BÍZIK, J.: Teoretická elektroenergetika II. STNL Praha, Alfa Bratislava 1978.
- [4] FACTS – Powerful systems for flexible power transmission. [online]. <[http://www05.abb.com/global/scot/scot221.nsf/verifydisplay/b0f2c8c94b48a6bcc1256fda003b4d42/\\$file/facts\\_%20eng.%20abb%20review.pdf](http://www05.abb.com/global/scot/scot221.nsf/verifydisplay/b0f2c8c94b48a6bcc1256fda003b4d42/$file/facts_%20eng.%20abb%20review.pdf)>.
- [5] HINGORANI, N. G. – GYUGYI, L.: Understanding FACTS. ISBN: 0-7803-3455-8, IEEE Order No. PC5713.
- [6] TCSC Thyristor Controlled Series Compensation. Keeping grids together [online]: [[http://www05.abb.com/global/scot/scot221.nsf/verifydisplay/fdf0b019e1fe08a48325771f002dbfc5/\\$file/a02-0158.pdf](http://www05.abb.com/global/scot/scot221.nsf/verifydisplay/fdf0b019e1fe08a48325771f002dbfc5/$file/a02-0158.pdf)].
- [7] CINTULA B.: Analýza dynamickej stability synchronného generátora [online]. <<http://www.posterus.sk/?p=11726>>.
- [8] SONG, Y. H. – JOHNS, T. A.: Flexible ac transmission systems (FACTS). London: IEEE Press, 1999. 592 s. ISBN 0-85296-771-3.
- [9] KIROV, R., – GYUROV, V. – CHIKOV, V. – MAKEDONSKI, N.: Study and Analyze of the Electrical Energy Efficiency by Minimum Active Power Criteria, International Scientific Conference „Unitech 2011“, Gabrovo, Republic of Bulgaria, 2011, Proceedings Vol. I, p. I 110- I 113, ISSN 1313-230X.
- [10] KHEDERZADEH, M.: Application of TCSC to enhance power quality [online]. In: Universities Power Engineering Conference, 2007. 42nd International, UPEC 4-6 Sept. 2007. s. 607. [online]: <[http://ieeexplore.ieee.org/xpl/freeabs\\_all.jsp?arnumber=4469017](http://ieeexplore.ieee.org/xpl/freeabs_all.jsp?arnumber=4469017)>.
- [11] FACTS – Flexible AC Transmission Systems: Series Compensation. Erlangen: Siemens AG, 2010. [online]: <[http://www.energy.siemens.com/us/pool/hq/powertransmission/FACTS/FACTS\\_Series\\_Compensation.pdf](http://www.energy.siemens.com/us/pool/hq/powertransmission/FACTS/FACTS_Series_Compensation.pdf)>.
- [12] GYUROV, V. – KIROV, R. – SULEIMAN, S.: Optimal Location of Reactive Power Compensators in Electrical Distribution Systems, International Conference “Electroenergetika” 2009, Proceedings, p. 77-78, Stara Lesna, Republic of Slovak, ISBN 978-80-553-0237-9.
- [13] KIROV, R. – GYUROV, V. – MAKEDONSKI, N. – CHIKOV, V.: Modeling of Power Balance Equation Using Theory of Experiment Planning, International Scientific Symposium of Electric Power Engineering, Elektroenergetika 2011, Stara Lesna, Slovak Republic, Proceeding of Paper, p. 184-189, ISBN 978-80-553-0724-4.

Received December 29, 2012, accepted June 19, 2013

#### BIOGRAPHIES

**Zsolt Čonka** is a Ph.D. student in the Department of Electric Power Engineering on the Faculty of Electrical Engineering and Informatics at Technical University in Košice. He received a master degree in electric power engineering on subject improving transient stability. His scientific research is mainly focused on research of special devices for power flow.

**Michal KOLCUN** was born in 1954 in Ruska Vola nad Popradom. In 1979 he graduated at the Faculty of Electric Power Engineering of the Moscow Power Engineering Institute. In 1989 he defended his PhD on the same institute in Moscow. In 1993 he habilitated to associated professor at the department of Electric Power Engineering on the Faculty of Electrical Engineering and Informatics at Technical University in Košice. In 2000 he inaugurate to professor, in the field of Power Engineering and Energetics, at the Faculty of Electrical Engineering and Informatics at Technical University in Košice. Since 2006 he is honorary professor at ÓBUDA University in Budapest, Hungary. Since June, 2012 he is Doctor Honoris Causa from Politechnika Czestochowa, Poland. Since 1979 he is working at the Department of Electric Power Engineering on the Faculty of Electrical Engineering and Informatics at Technical University in Košice. His scientific research is focusing on a power system control and computer application in electric power engineering. In addition, he also gives lectures in multiple foreign universities in Moscow, Sankt Peterburg, Czestochowa, Zelona Gorza, Budapest, Riga, Tallinn, Varna, Prague, Ostrava and Barcelona.